



International journal of basic and applied research

[www.pragatipublication.com](http://www.pragatipublication.com)

ISSN 2249-3352 (P) 2278-0505 (E)

Cosmos Impact Factor-5.86

# A Novel ANN based Hybrid PV based Compensator for Grid Power quality enhancement

Bhukya Vinod<sup>1</sup>, P Purnachander Rao<sup>2</sup>

1, PG Student, Department of Electrical and Electronics Engineering

2, Assistant Professor, Department of Electrical and Electronics Engineering

Vaagdevi College of Engineering Bollikunta, Warangal(Dt), TS, India.

[vinodbhukya003@gmail.com](mailto:vinodbhukya003@gmail.com)

## Abstract:

Improving power quality (PQ) in grid-interfaced systems is a critical concern in modern power systems. This Thesis presents a novel approach using a custom power device to enhance system reliability and power quality. The photovoltaic (PV) system is chosen as a distributed generation (DG) source due to its availability, efficiency, and cost-effectiveness. In addition, a hybrid fuzzy proportional-integral (PI) controller, based on the cuckoo search algorithm, is introduced to regulate the DC link voltage of the custom power device (CPD). This hybrid ANN with PI controller is designed to outperform conventional fuzzy logic controllers by offering superior tracking efficiency and dynamic response. The proposed DG system, featuring the cuckoo-based hybrid ANN based PI controller is tested in MATLAB, demonstrating improved power quality and system performance compared to systems employing traditional fuzzy controllers.

**Key words:** Power Quality, Photovoltaic system, Custom power devices and ANN controller

## I. Introduction

Electric power distribution networks have been greatly disrupted by the increasing number of non-linear loads that use power electronic components. In addition, there is a noticeable increase in reactive power consumption, current imbalance, harmonic emissions, and harmonics. Electrical grids are susceptible to voltage harmonics and disturbances caused by harmonic currents. Numerous loads susceptible to harmonic currents, such as control systems, protection



circuits, and equipment in the power system, can be adversely affected by these currents. Consumers and energy distributors alike were wary of new regulations meant to curb the spread of harmonic problems.

There have been a lot of proposed solutions to the problem of harmonics. These methods included changing the load in order to lower harmonic emissions, using rectifiers with 1 $\Phi$  and 3 $\Phi$  stages, PWM rectifiers, or integrating different compensation systems, either old or new, with polluted power networks.

Problems with power quality, especially those associated with harmonics, have prompted a plethora of research efforts aimed at developing modern, flexible, and more effective solutions. These modern solutions are known as active power filters or active compensators. Active power filters, or STATCOMs for short, primarily function to reduce reactive power imbalance and harmonic currents and voltages.

Harmonic compensation has made use of a plethora of STATCOM versions. Voltage harmonic correction makes use of the STATCOM series. Modifying reactive power and current harmonics was suggested by the Shunt STATCOM. An all-in-one solution for rectifying reactive power, current harmonics, and voltage, the Unified Power Quality Filter or Conditioner combines the best features of Shunt and Series STATCOM. The Shunt STATCOM is still the most well-known and popular STATCOM version, even if there are others. Reducing power grid harmonic currents is D-Statcom's principal function. The basic idea behind SSTATCOM is to generate harmonic currents that are symmetrical in phase and of comparable magnitude to the grid's circulating harmonics. Currents drawn from the grid by non-linear loads are not sinusoidal. The generation of the SSTATCOM current ensures that the grid current continues to follow a sinusoidal waveform. The regulation states that SSTATCOM must be seen by the grid as a linear resistive load even when the load is non-linear.

Two main structures exist for controlling the Shunt Active Power Filter: the direct control and the indirect control of STATCOM. Direct control primarily aims to generate filter current references using appropriate approaches. The STATCOM currents that were measured were compared to the  $I_{ref}$ . In the end, the defect is used to make filter control signals. Grid currents, instead of filter currents, are indirectly controlled. In it, the generated grid currents are shown



next to the measured ones. The STATCOM control signal is determined once the error is delivered to the control circuit.

This study examines the effects of reactive power, current harmonics, and current on power quality, and then finds ways to fix these problems with shunt active power filters. The goal is to feed as much renewable energy as possible into the AC grid. Study Objectives My thesis mainly aims to integrate STATCOM functionalities into the traditional four-leg voltage source inverter so that renewable energy sources like wind and solar cells can be connected to the grid without spending extra money on hardware. When used properly, the grid interface inverter may carry out the following essential tasks: To provide the load with active power. Specifically, at the point of common coupling (PCC), to reduce reactive power and current harmonics in the load. To fix the three-phase, four-wire system's current imbalance and neutral current.

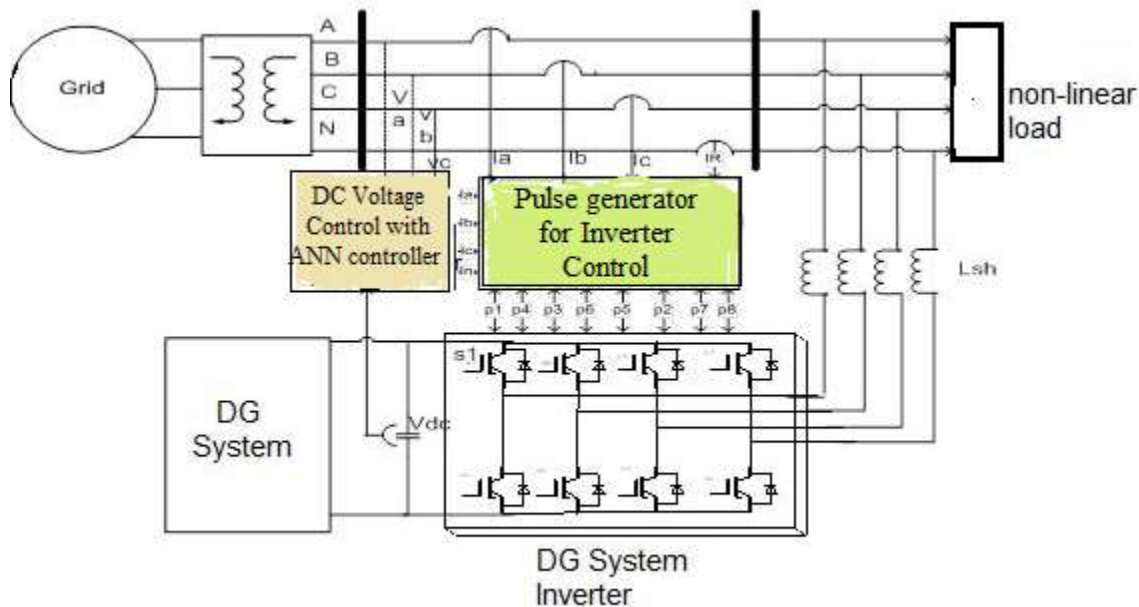

Figure 1 Grid Tied PV system

### a) Literature Review

Johan H. R. Enslin investigated harmonic transmission between various networks and converters [1]. The primary objectives of this study are to assess the claimed occurrence of harmonic



interference across large populations of inverters and to examine the network interactions of various inverter topologies and monitoring techniques.

The authors Uffe Borup and Frede Blaabjerg looked at how linear and nonlinear loads are distributed in three-phase power converters [2] that are linked in parallel but do not communicate with each other. When two harmonic-compensating converters are linked in parallel, the problem is addressed in the study.

With Pichai Jintakosonwit, Hideaki Fujita, Hirofumi Akagi, and Satoshi Ogasawara from Google [3]. A cooperative control technique for multiple active filters using voltage detection to minimise power distribution system harmonics is presented in this work. Depending on the operational conditions and potential fault scenarios, the configuration of a real distribution system would be changed. In addition, the distribution system is either not connected to the shunt capacitors or the loads at all.

In instances when the voltage is imbalanced and distorted, Pedro Rodríguez, Josep Pou, Joan Bergas, J. Ignacio Candela, Rolando P. Burgos, and Dushan Boroyevich detailed how to detect the positive-sequence component of the fundamental frequency [4]. The novel decoupled double synchronous reference frame phase-locked loop (PLL) it employs is a positive-sequence detector that does away with the detection errors caused by conventional synchronous reference frame PLLs. To do this, we first convert the utility voltage's positive and negative sequence components into a double synchronous reference frame. Then, we build a decoupling network to effectively separate the two sequences.

The authors Soeren Baekhoej Kjaer, John K. Pedersen, and Frede Blaabjerg analyse grid-connected inverters for solar modules that operate on a single phase [5]. In this research, we look at inverter systems that connect PV modules to a single-phase grid. There are four ways inverters can be categorised: 1) by the number of cascaded power processing stages; 2) by the method of power decoupling between the photovoltaic modules and the single-phase grid; 3) by the presence or absence of a transformer (either line or high frequency); and 4) by the type of grid-connected power level.

R. C. P. Guisado, E. Galván, J. T. Bialasiewicz, L. G. Franquelo, M. Á. M. Prats, J. I. León, and N. M. Alfonso are the authors of the following. According to this research, decentralised energy



resources are being seen more and more as a viable alternative to large-scale conventional power plants [6]. Particularly in cases where the intermittent energy source accounts for a significant amount of the total system capacity, specifications for power electronic interfaces are impacted by needs related to the renewable energy source as well as its influence on power system performance.

## II. Solar Panel

The solar system is among the most dependable systems within the renewable energy sector. The solar system produces

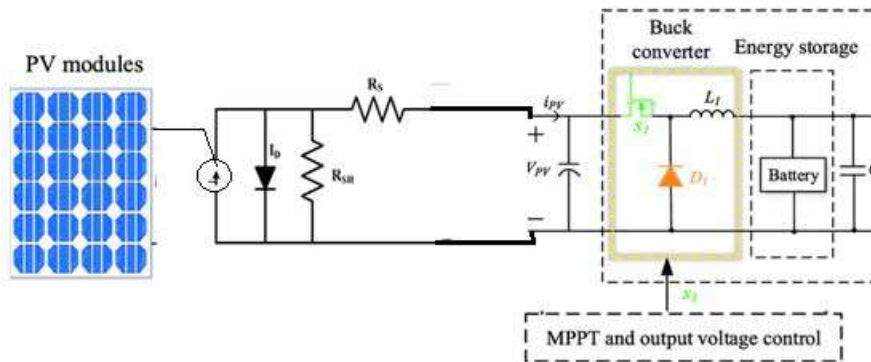

Figure 2 Structure of PV based boost converter

$$I_{solar} = I_{ph} - I_D - I_{sh}$$

$$I_{solar} = I_{ph} - I_o \left[ e^{\left( \frac{qV_D}{nKT} \right)} \right] - \left( \frac{V_D}{R_s} \right)$$

The solar electric equivalent circuit converts solar current into photovoltaic voltage, as illustrated in Fig. 2. The primary drawback of this solar system is the challenge of attaining consistent electricity from solar sources. This paper proposes a dc-dc converter to regulate the solar voltage to a consistent level. An MPPT technique is employed in the boost converter to optimise power extraction from the photovoltaic system.



Figure 2 illustrates the MPPT-based photovoltaic system [1]. This work implements a Cuckoo Search-based MPPT controller to create the duty cycle necessary for the boost converter to optimise power extraction from the solar system.

Maximum Power Point Tracking Technique, The objective of the MPPT approach is to formulate an appropriate reference signal necessary for the PWM of a DC-DC converter, hence enhancing the efficiency of distributed generation systems and battery charging controllers. This work offers an MPPT controller [2] and compares the performances of several MPPT algorithms selected for analysis. (a) Cuckoo Algorithm.

#### **a) Cuckoo Algorithm**

Cuckoos are intriguing birds due to their vocalisations and assertive reproductive practices. Cuckoos typically deposit their eggs in communal nests and may eliminate other eggs to enhance the hatching probability of their own eggs. Female cuckoos identify and choose a cohort of host species with analogous nesting places and egg characteristics to their own, thereafter choosing the most suitable nests from this selection.

Cuckoos initiate the search for the optimal nest, a crucial stage that plays a significant part in their reproductive strategy. The Lévy flight is crucial in locating optimal nests and food sources. The step length or Lévy flight distribution is articulated.

$$S = \alpha_q (V_{br} - v_j) \oplus le(\lambda)$$

$$V_i^{t+1} = V_i^t + \alpha \oplus levy(\lambda)$$

#### **b) Custom Power Device and Control Structure**

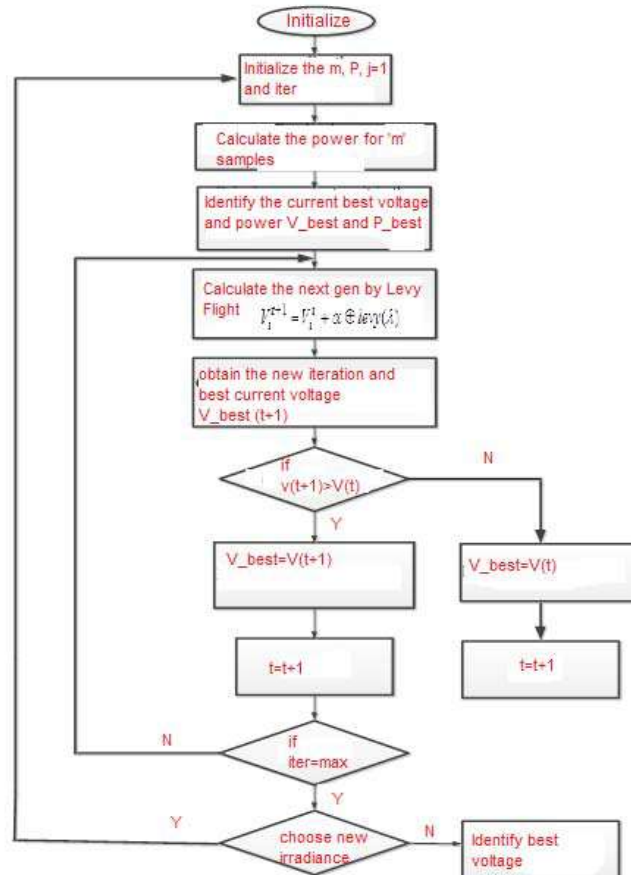

Figure 3 Cuckoo Search Algorithm

Improving power quality for clients is the goal of a custom power device (CPD), which combines a power electronic regulator with a capacitor damper [8]. The capacity of voltage source interfaces (VSIs) to self-regulate the voltage of a DC bus controller makes them an ideal component for power electronic converters. CPD can be classified into two main types: a) Two Types of Network Reconfiguration and Compensating Variations in load, system properties, and switching scenarios are the most common causes of power quality problems. Various load situations, including imbalanced and non-linear loads, are managed by the proposed grid system that incorporates photovoltaic (PV) technology.

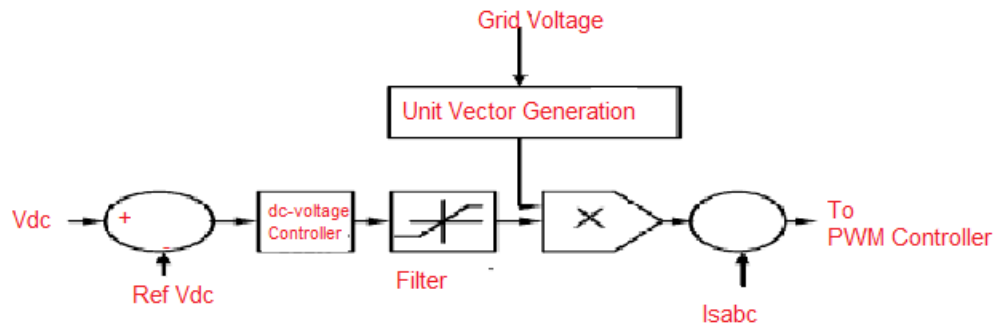

Figure 4 Control Diagram for CPD

One of the many shunt controllers is the DSTATCOM. It consists of a capacitor and a voltage-switched interfacing (VSI) converter that are linked together with the current setup. In distribution networks, DSTATCOM absorbs or delivers reactive power to reduce bus voltage sag. Fig. 3 shows the DSTATCOM configuration.

In order to reduce power quality problems, the power inverter in DSTATCOM changes the direct current voltage into an alternating current voltage that may be controlled. This filtered voltage is then linked to the distributed generating system. As shown in Figure 4, the shunt controller's control diagram is built around the concept of regulating DC voltage. A typical controller is shown in Fig. 4 applying the system's DC voltage, which is regulated using a standard voltage. Using data from the grid system, the reference 3Φ currents are derived using the idea of a unit vector [4]. The mathematical study of producing unit vectors.

$$V_{sm} = \frac{2}{3} (V_{as}^2 + V_{bs}^2 + V_{cs}^2)^{0.5}$$

$$U_{sa} = \frac{V_{sa}}{V_{sm}}, U_{sb} = \frac{V_{sb}}{V_{sm}} \text{ and } U_{sc} = \frac{V_{sc}}{V_{sm}}$$

The inverse of the sine of the angle of incidence between the V and I in a circuit with alternating current is equal to the power factor, which is the ratio of actual power to volt-amperes. The sinusoidal V and I define these clearly defined quantities. Capacitors, when connected to the





power line, draw the highest current and supply lagging VARs, improving the power factor. Adjusting VAR and levels of voltage is as simple as activating or deactivating power factor adjustment capacitors.

The ratio of the active power to the perceived power is called the power factor associated with a sinusoidal signal. In most cases, nominal V & I will be used to describe electrical equipment parameters. Inefficient use of a device could be indicated by a low power factor. How powerful someone seems is determined by

$$S = V_{rms} \cdot I_{rms} = V_{rms} \cdot \sqrt{\frac{1}{T} \int_0^T i_L^2 dt}$$

$$P = V_{rms} \cdot I_{rms} \cdot \cos(\alpha)$$

$$Q = V_{rms} \cdot I_{rms} \cdot \sin(\alpha)$$

$$P.F = \frac{P}{S} = \frac{P}{\sqrt{P^2 + Q^2}}$$

$$D = V_{rms} \cdot \sqrt{\sum_{n=2}^{\alpha} I_{Ln}^2}$$

$$S = \sqrt{P^2 + Q^2 + D^2}$$

$$P.F = \frac{P}{\sqrt{P^2 + Q^2 + D^2}}$$

Power factor diminishes due to the presence of harmonics alongside reactive power consumption.

### III. ANN based controller



To address these concerns, a controller based on a Artificial Neural Network (ANN) can be developed to enhance the APF's real-time accuracy and adaptability. Input parameters like voltage, current, and harmonic distortions can be "learnt" by the ANN-based controller, which allows it to respond faster to dynamic changes in load circumstances and power system disruptions; and learn complicated relationships between these input parameters. Improved power factor correction and harmonic mitigation can be achieved by more precisely predicting compensatory currents.

Parts of Artificial Neural Network-Based APF Control:

1. Patterns for Artificial Neural Networks:
  - Signals of voltage (supply voltage and load voltage) for the purpose of detecting voltage disturbances and harmonics.
  - Signals of current (from both the load and the APF) in order to examine the waveform of the current and identify any harmonic content or distortions.
  - The level of harmonic distortion, abbreviated as THD. In order to determine reactive power compensation, one must know the phase angle of the current and voltage waveforms.
2. ANN Training:
  - The power system's historical data is gathered under a variety of operating settings, such as different types of loads and levels of harmonic distortion.
  - A For the purpose of training the ANN, supervised learning methods such as backpropagation are utilised. The inputs to the algorithm represent the measured system parameters, while the outputs represent the necessary compensating signals.
3. Operation in Real Time:
  - After training, the ANN uses real-time inputs (such as voltage, current, and harmonics) to forecast the ideal compensatory current that will reduce harmonics and enhance power quality.
  - A The APF's pulse-width modulation (PWM) is controlled by the ANN's output, guaranteeing precise and rapid harmonic current correction.



#### IV. Simulation Analysis

The results of a hybrid system's implementation of Continuous Power Distribution (CPD) under classical Fuzzy Logic Control (FLC) and ANN Controller, with a nonlinear load, are shown in Figures 5–9. Using a non-linear load, the system is put into action. The grid current is affected by harmonics throughout the time interval from  $t=0.3$  to  $t=0.6$  seconds since no compensator is used. The CPD is included into the system after  $t=0.6$  seconds, reducing grid harmonics.

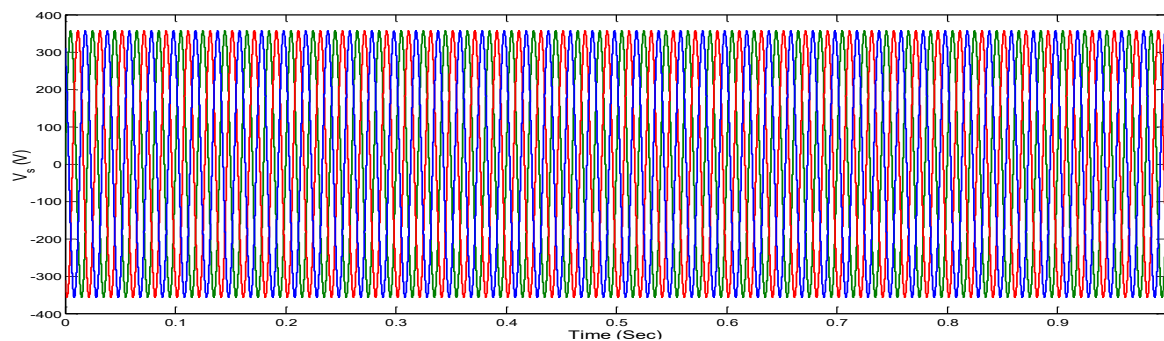

Figure 5 Source Voltage

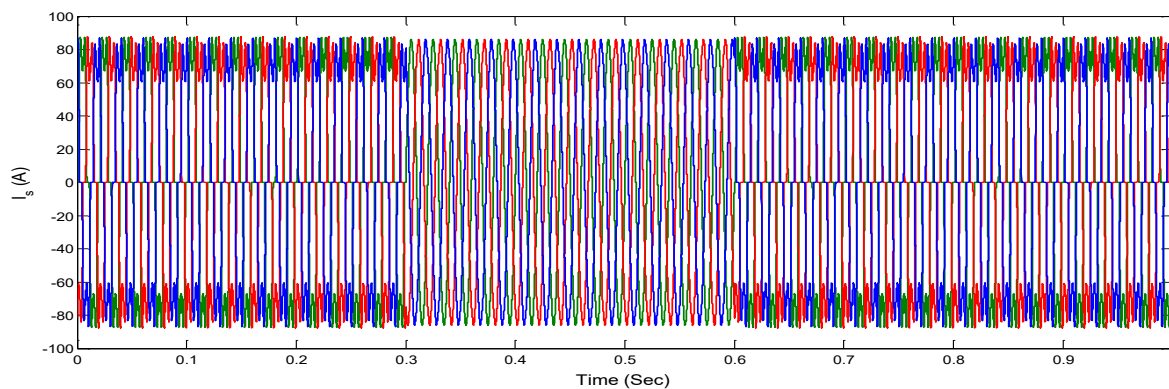

Figure 6 Source Current

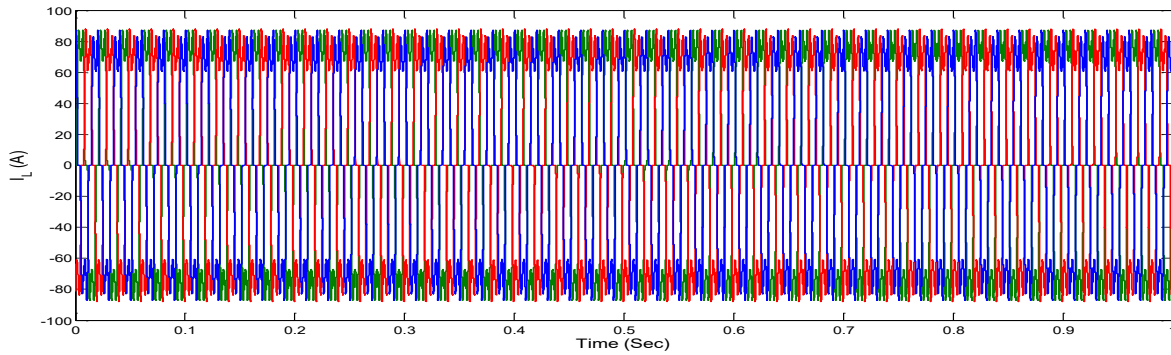

Figure 7 Load Current

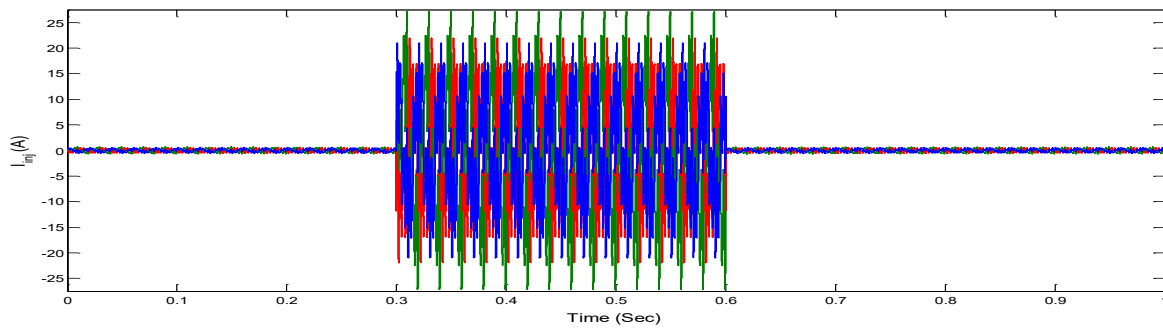

Figure 8 Injected current

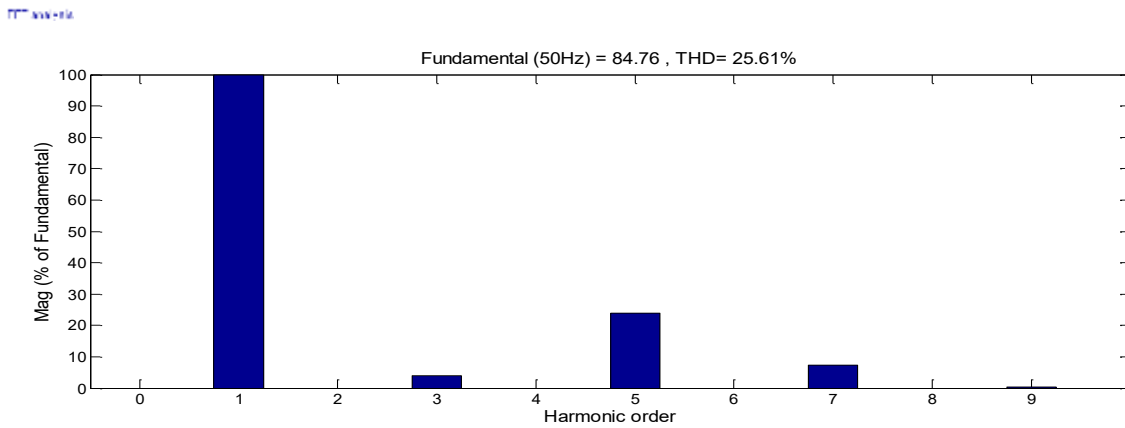

Figure 9 THD for Load Current

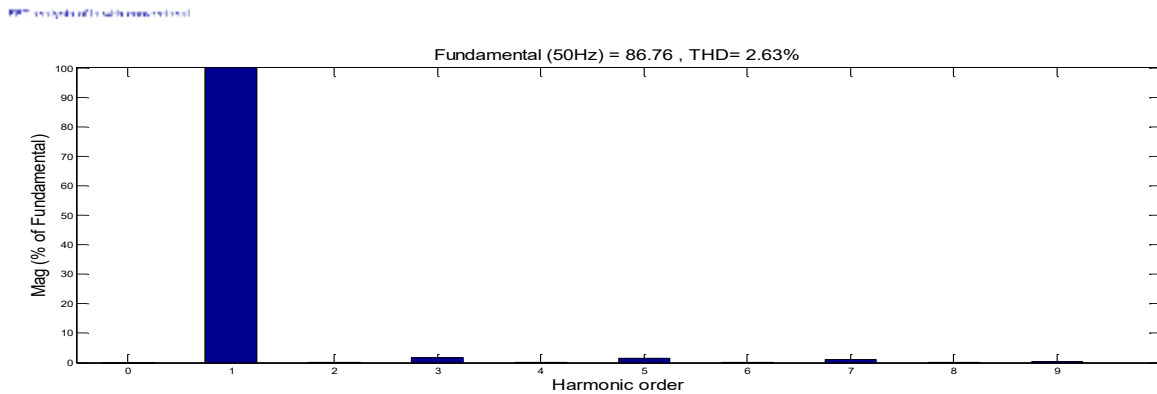

Figure 10 THD For Grid Current with Cuckoo based Fuzzy controller

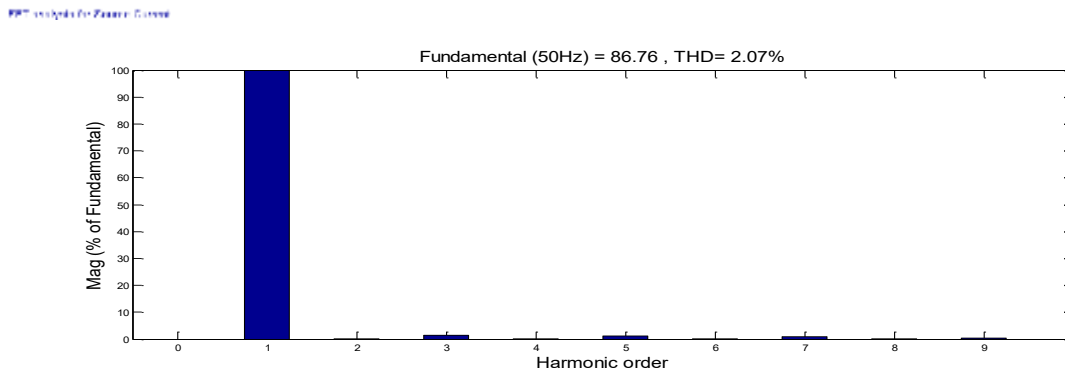

Figure 11 THD for Current with ANN based Cuckoo controller

Figures 9-11 show the results of the total harmonic distortion (THD) study of grid current in a PV-Grid system operating with non-linear loads, with and without controllers. For a load current, the total harmonic distortion (THD) is 25.61%; for a DSTATCOM controller based on fuzzy logic, it is 2.63%; and for an ANN-based controller, it is 3.07%.

## V. Conclusion

In conclusion, the study demonstrates that a DC-coupled system with a grid-interfacing inverter can effectively enhance power quality at the point of common coupling (PCC) in a 3-phase 4-wire distributed generation system. By utilizing the inverter for both real power transfer from renewable energy sources (RES) and power conditioning as a shunt Active Power Filter (APF), the system eliminates the need for additional power conditioning equipment. The



MATLAB/SIMULINK simulation model validated this approach, incorporating an advanced control circuit that includes a phase lock loop, proportional-integral controller, and hysteresis controller for precise gate pulse generation. Furthermore, integrating a neural network with cuckoo optimization in place of fuzzy logic enabled adaptive control, optimizing real-time parameter adjustments and enhancing compensation accuracy. This combined approach significantly improved system performance by mitigating current unbalance, harmonics, and reactive power associated with unbalanced and non-linear loads, ensuring balanced and sinusoidal grid-side currents with unity power factor. The findings underscore the reliability and efficiency of integrating RES with improved power quality at the PCC, reducing the dependency on complex power conditioning devices.

## References

- [1] J. H. R. Enslin and P. J. M. Heskes, “Harmonic interaction between a large number of distributed power inverters and the distribution network,” *IEEE Trans. Power Electron.*, vol. 19, no. 6, pp. 1586–1593, Nov. 2004.
- [2] U. Borup, F. Blaabjerg, and P. N. Enjeti, “Sharing of nonlinear load in parallel-connected three-phase converters,” *IEEE Trans. Ind. Appl.*, vol. 37, no. 6, pp. 1817–1823, Nov./Dec. 2001.
- [3] P. Jintakosonwitt, H. Fujita, H. Akagi, and S. Ogasawara, “Implementation and performance of cooperative control of shunt active filters for harmonic damping throughout a power distribution system,” *IEEE Trans. Ind. Appl.*, vol. 39, no. 2, pp. 556–564, Mar./Apr. 2003.
- [4] P. Rodríguez, J. Pou, J. Bergas, J. I. Candela, R. P. Burgos, and D. Boroyevich, “Decoupled double synchronous reference frame PLL for power converters control,” *IEEE Trans. Power Electron.*, vol. 22, no. 2, pp. 584–592, Mar. 2007.
- [5] S. B. Kjaer, J. K. Pedersen, and F. Blaabjerg, —A review of single-phase grid-connected inverters for photovoltaic modules, *IEEE Trans. Ind. Appl.*, vol. 41, no. 5, pp. 1292–1306, Sep./Oct. 2005.
- [6] F. Blaabjerg, R. Teodorescu, M. Liserre, and A. V. Timbus, “Overview of control and grid synchronization for distributed power generation systems,” *IEEE Trans. Ind. Electron.*, vol. 53, no. 5, pp. 1398–1409, Oct. 2006.
- [7] J. M. Carrasco, L. G. Franquelo, J. T. Bialasiewicz, E. Galván, R. C. P. Guisado, M. Á. M. Prats, J. I. León, and N. M. Alfonso, “Power electronics systems for the grid integration of



- renewable energy sources: A survey,” *IEEE Trans. Ind. Electron.*, vol. 53, no. 4, pp. 1002–1016, Aug. 2006.
- [8] B. Renders, K. De Gusseme, W. R. Ryckaert, K. Stockman, L. Vandeveld, and M. H. J. Bollen, “Distributed generation for mitigating voltage dips in low-voltage distribution grids,” *IEEE Trans. Power.Del.*, vol. 23, no. 3, pp. 1581–1588, Jul. 2008.
- [9] V. Khadkikar, A. Chandra, A. O. Barry, and T. D. Nguyen, “Application of UPQC to protect a sensitive load on a polluted distribution network,” in *Proc. Annu. Conf. IEEE Power Eng. Soc. Gen. Meeting*, 2006, pp. 867–872.
- [10] M. Singh and A. Chandra, “Power maximization and voltage sag/swellride-through capability of PMSG based variable speed wind energy conversion system,” in *Proc. IEEE 34th Annu. Conf. Indus. Electron.Soc.*, 2008, pp. 2206–2211.
- [11] J. P. Pinto, R. Pregitzer, L. F. C. Monteiro, and J. L. Afonso, “3-phase4-wire D-Statcom with renewable energy interface,” presented at the Conf. IEEE Renewable Energy & Power Quality, Seville, Spain, 2007.
- [12]. M. Calais, J. Myrzik, T. Spooner, and V. G. Agelidis, —Inverters for single-phase grid connected photovoltaic systems—An overview,|| in *Proc. 33th IEEE Power Electronics Specialists Conf. (PESC’02)*, Cairns, Australia, June 23–27, 2002.